



H O I S T

Uni-Hoist Stainless Steel Lift Systems



Materials Handling
Solutions

hanningfield



Materials Handling Solutions

The **Uni-Hoist** is arguably Hanningfield's signature product, with over 150 systems installed worldwide. The versatility and reliability of the lift system has led the **Uni-Hoist** to become the natural solution for materials handling problems for a broad spectrum of industry leaders.

The **Uni-Hoist** range of stainless steel lift systems provides the ideal solution for repetitive lifting and positioning of process equipment and machinery such as mixers, vacuum transfer hoppers, and mills etc. The **Uni-Hoist** relies upon a carefully designed structure which enables the system to cope with standard load capacities of up to 1,250kgs. This makes the **Uni-Hoist** suitable for almost any process, helping to eliminate unsafe and tiring manual tasks.

The **Uni-Hoist** system has been specifically designed for the use in areas where space is restricted; thus the innovative design of the **Uni-Hoist** provides users with a versatile solution for a variety of materials handling applications.

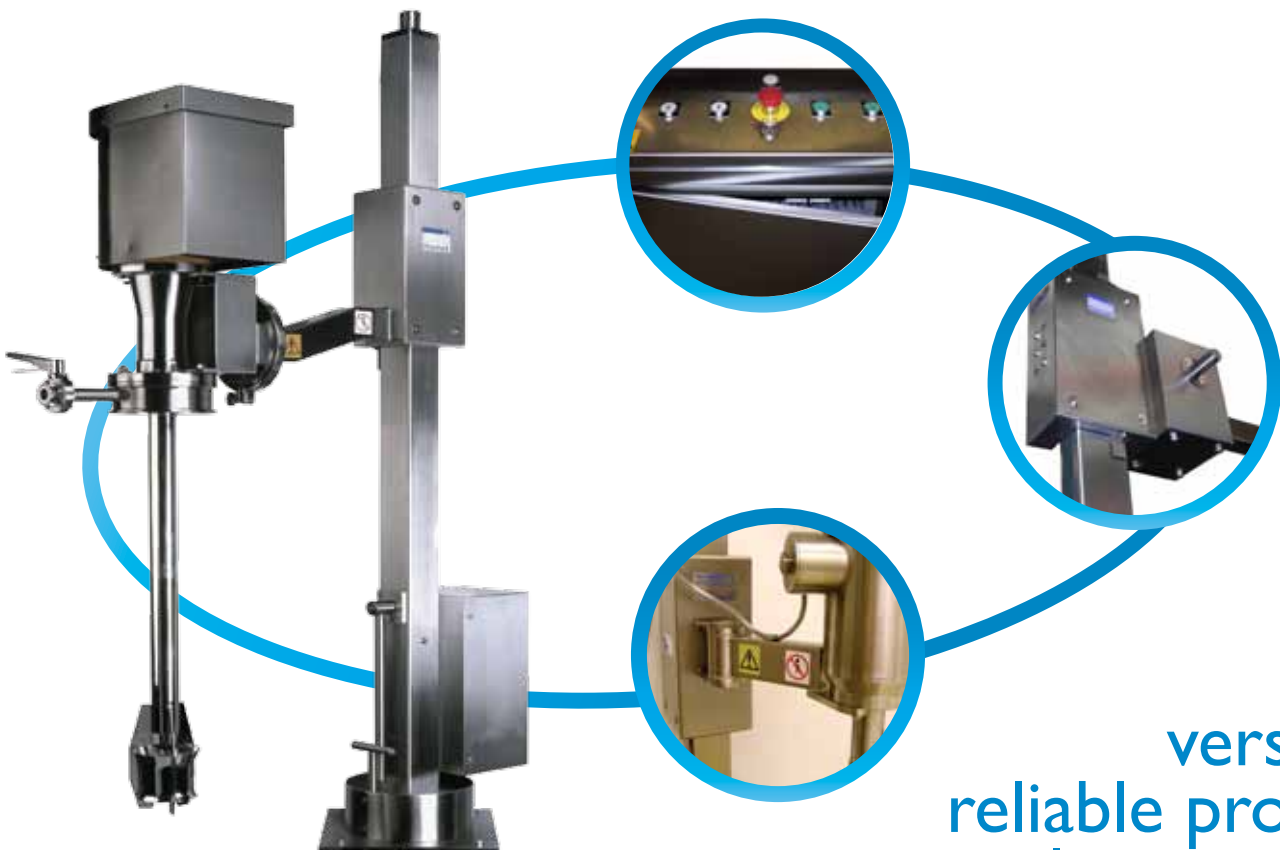

- ▶ Stainless steel construction
- ▶ Static and mobile versions
- ▶ Manual or powered operation
- ▶ Custom designs available
- ▶ IBC handling systems
- ▶ Drum handling systems
- ▶ GMP easy clean design
- ▶ Totally enclosed lifting mechanism

versatile
reliable process
solutions from
Hanningfield



The **Uni-Hoist** range now has two separate designs. A lightweight version for loads up to approximately 600kgs and a heavy duty version for loads up to 1250kgs. Smaller hoists can be manually operated to provide a cost effective solution for light loads.

The **Uni-Hoist** lift system offers a compact and versatile solution to process equipment handling problems. Our success is a result of quality, reliability and attention to detail, backed up by first class service and support.

Every application and customer requirement can be different, we can therefore design and custom build the **Uni-Hoist** system to any specification including ATEX.

The **Uni-Hoist** system is ideal for use as an integrated system with various types of processing equipment such as mills, mixers and silos. The system is also perfect for lifting IBC's above process machines such as tablet presses and Capsule filling machines.

- IBC handling
- Drum handling
- Tablet press loading
- Lift turn and invert

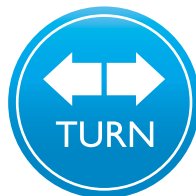

- ▶ Raise and lower process equipment for maintenance and cleaning
- ▶ Raise and position IBC's for loading by gravity into process machines
- ▶ Hygienic and easy to clean and maintain
- ▶ Totally enclosed lifting mechanism
- ▶ Stainless steel construction
- ▶ Invert product drums for discharge by gravity
- ▶ Accurately raise and lower mixers into mixing vessels

IBC raised above
a tablet press

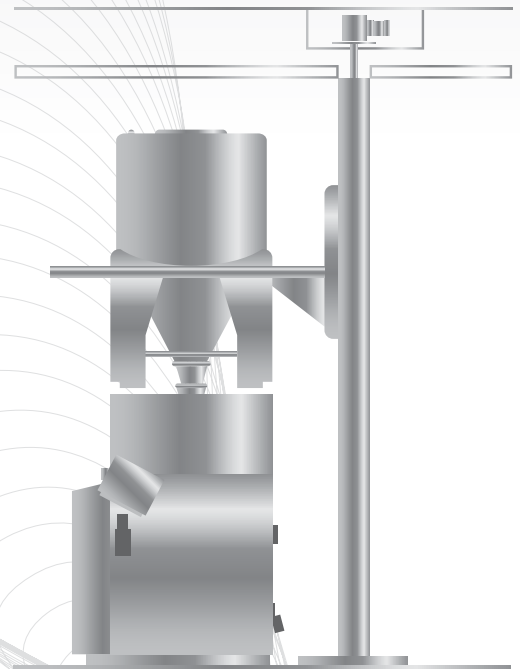

Variations

mobile // static // wall mounted
electric // pneumatic

Features

easy to clean // stainless steel
construction // low maintenance

